  
**MINETEC**  
MINING & TECHNOLOGY

## OUR COMPANY

MINETEC began operating in the year 2007, manufacturing products in the field of mineral extraction, quarry and earthmoving equipment, supported by highly qualified engineering and state of the art technology. MINETEC designs and manufactures customised solutions for the mining industry, optimising earthmoving equipment components to reach the best performance.

MINETEC's products which outstand are buckets for shovels and dippers, critical components of shovels and loaders, dump trays for mining trucks and a full range of maintenance services with field support for these equipments.

MINETEC has made extraordinary developments in the mining industry thanks to the effort of all it's team. At MINETEC we encourage hard and intensive team work, high individual and group responsibility, perseverance, creativity, the use of state of the art technology and fair play.



Dump Tray Minetec TKS\_960 – Hail Creek, Rio Tinto, AUSTRALIA.  
Front Photo: Bucket BCT\_7495, Peñasquito, Goldcorp, MEXICO.

# COMPONENT MANUFACTURE FOR ROPE SHOVELS

*COMPATIBLE WITH P&H SHOVELS*

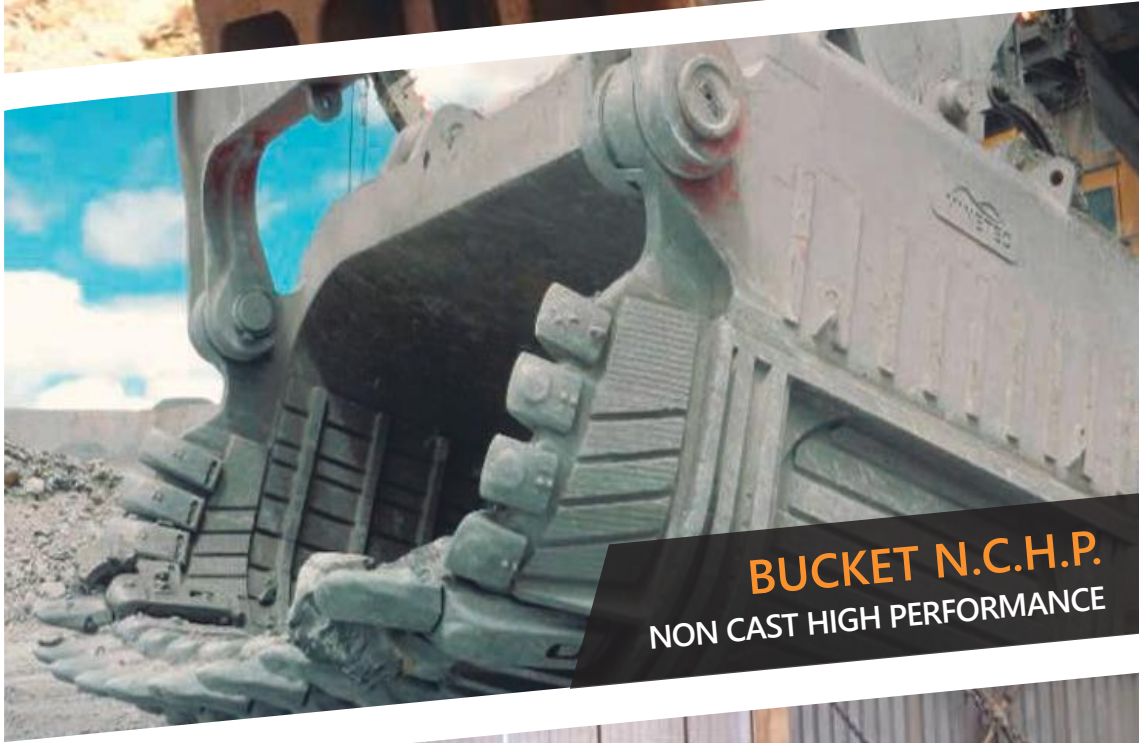

**BUCKET N.C.H.P.**  
NON CAST HIGH PERFORMANCE



**MINETEC**

# MAJOR COMPONENTS FOR ROPE SHOVELS COMPATIBLE WITH P&H SHOVELS

## ■ Minetec Bucket **NCHP** compatible with P&H shovels:

- 4100 XPC
- 4100 XPB
- 2800
- 2300

Among other models.



## ■ Minetec Dipper Handle compatible with P&H shovels:

- 4100 XPC
- 4100 XPB
- 2800
- 2300

Among other models.



## ■ Minetec NCH Bucket Lip compatible with P&H shovels:

- 4100 XPC
- 4100 XPB

Among other models.

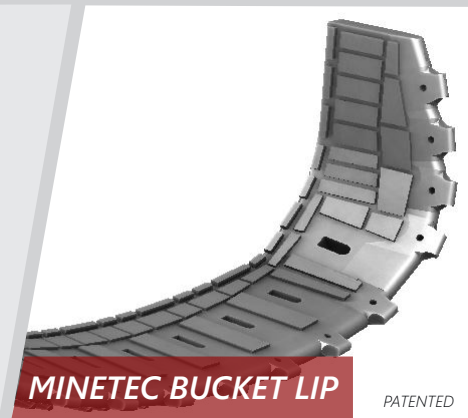

# PARTS AND PIECES FOR MINETEC NCHP BUCKET

COMPATIBLE WITH P&H SHOVELS/ REF. 4100 XPC

FOR OTHERS MODELS VISIT [WWW.MINE-TEC.COM](http://WWW.MINE-TEC.COM) OR CONTACT A MINETEC DEALER

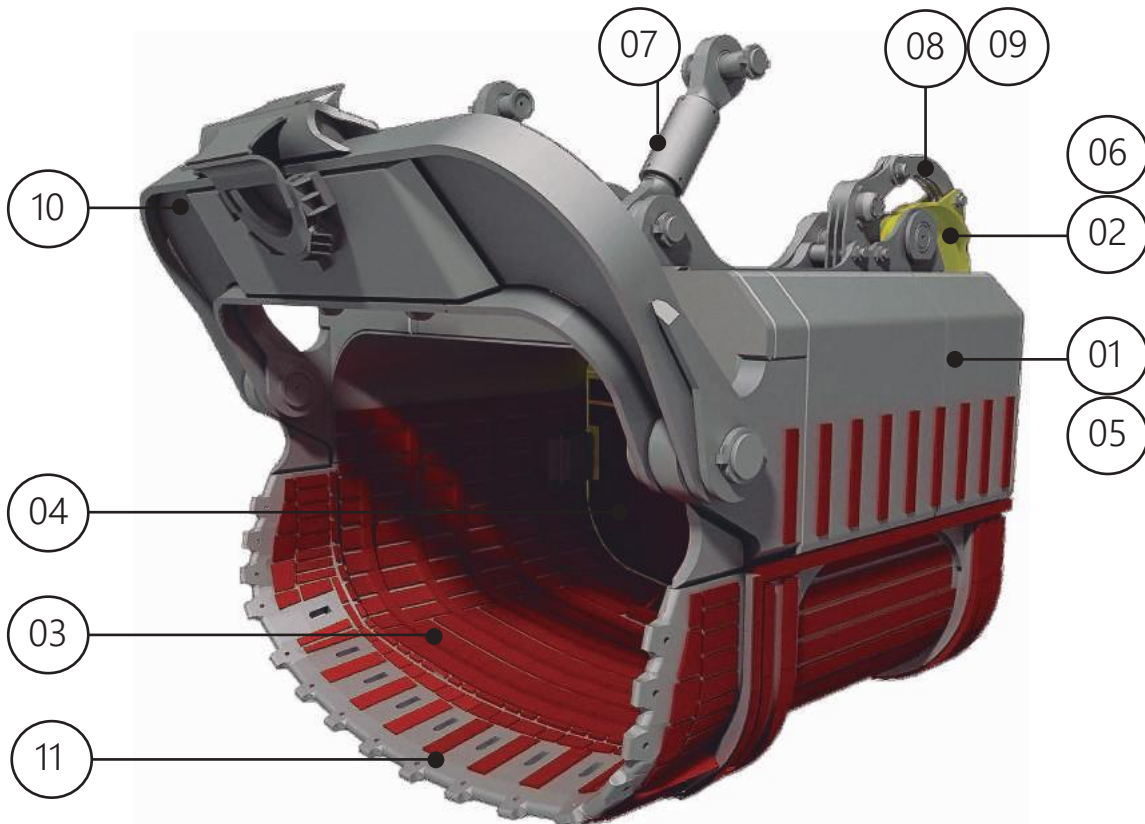

## MINETEC NCHP BUCKET/ PART NUMBER BPH\_V2-4100XPC-MI-00A

REF	DESCRIPTION	PART NUMBER	QTY
1	DIPPER BODY	BPH_V2-4100XPC-MI-01-00A	1
2	DIPPER DOOR	BPH_V2-4100XPC-MI-02-00A	1
3	BUCKET WEAR KIT	BPH_V2-4100XPC-MI-03-00A	1
4	DOOR WEAR KIT	BPH_V2-4100XPC-MI-04-00A	1
5	DIPPER ASSEMBLY	BPH_V2-4100XPC-MI-05-00A	1
6	DOOR ASSEMBLY	BPH_V2-4100XPC-MI-06-00A	1
7	PITCH BRACE	BPH_V2-4100XPC-MI-07-00A	2
8	SNUBBER - RIGHT	BPH_V2-4100XPC-MI-09-00A-D	1
9	SNNUBER LEFT	BPH_V2-4100XPC-MI-09-00A-I	1
10	BAIL	BPH_V2-4100XPC-MI-08-00A	1
11	DIPPER LIP	LPH_V2-4100XPC-MI-00A	1

## PARTS AND PIECES COMPATIBLE WITH P&H BUCKET

### ■ Minetec Dipper Door compatible with P&H bucket:

- 4100 XPC
- 4100 XPB
- 2800
- 2300

Among other models.



**MINETEC DIPPER DOOR**

### ■ Snubber Minetec **SENSOR 2X / 4X** compatible with P&H shovels:

- 4100 XPC
- 4100 XPB
- 2800
- 2300

Among other models.

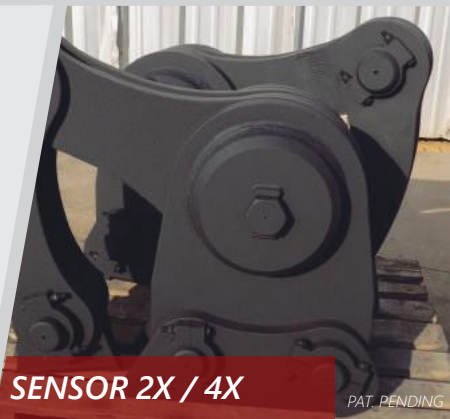

**SENSOR 2X / 4X**

### ■ Minetec adjustable Pitch Brace with P&H buckets:

- 4100 XPC
- 4100 XPB
- 2800
- 2300

Among other models.

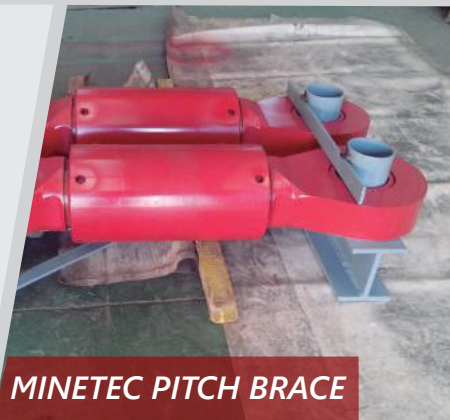

**MINETEC PITCH BRACE**

# PARTS AND PIECES MINETEC BUCKET DOOR

## REF. BUCKET 4100 XPC

FOR OTHERS MODELS VISIT [WWW.MINE-TEC.COM](http://WWW.MINE-TEC.COM) OR CONTACT A MINETEC DEALER

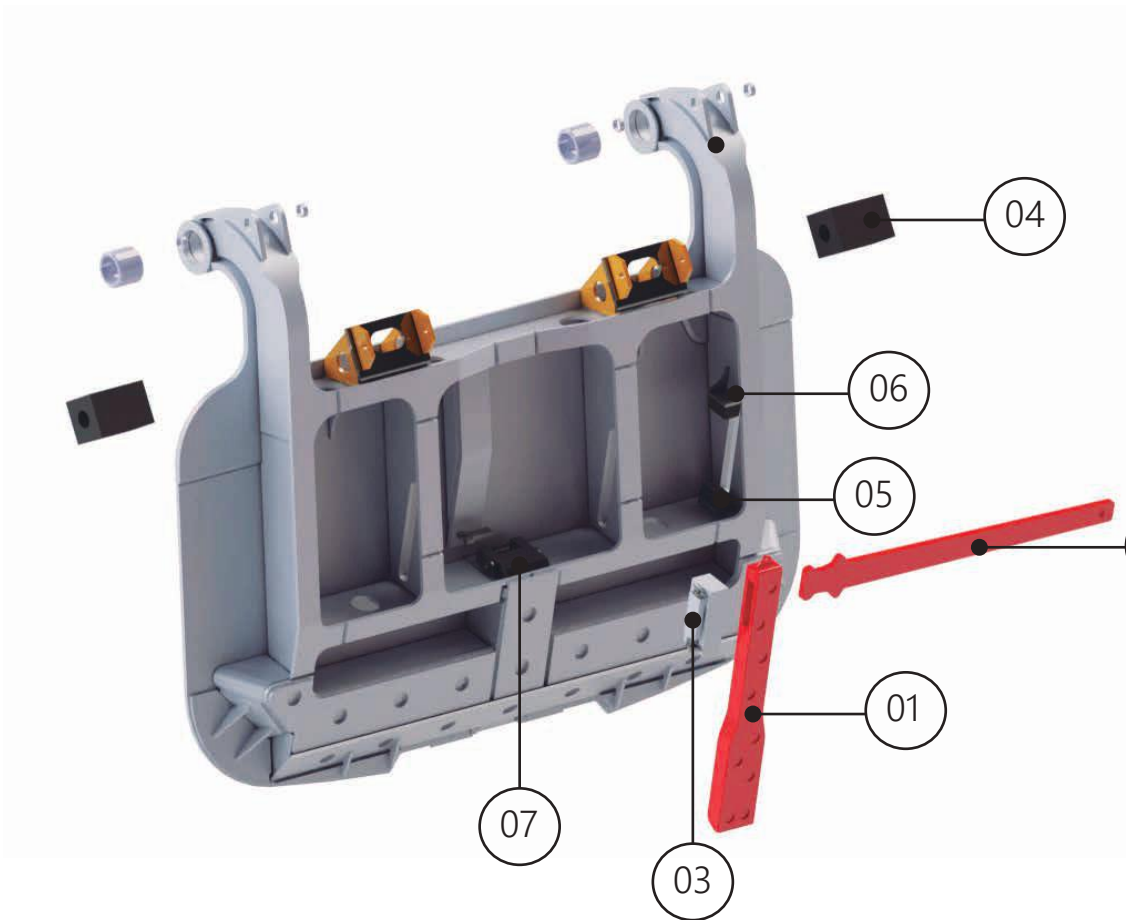

### MINETEC DIPPER DOOR WITH ACCESSORIES / PART NUMBER BPH\_V2-4100XPC-MI-06-00A

REF	DESCRIPTION	PART NUMBER	QTY
1	LATCH BAR	BPH_V2-4100XPC-MI-06-01-00A	1
2	LATCH LEVER	BPH_V2-4100XPC-MI-06-02-00A	1
3	LATCH LEVER RETAINER	BPH_V2-4100XPC-MI-06-04-00A	1
4	BOOM BUMPER	BPH_V2-4100XPC-MI-06-06-00A	2
5	LOWER LATCH BUMPER	BPH_V2-4100XPC-MI-06-07-00A	1
6	UPPER LATCH BUMPER	BPH_V2-4100XPC-MI-06-08-00A	1
7	LATCH GUIDE INSERT	BPH_V2-4100XPC-MI-06-09-00A	1

## SPARE PARTS AND ACCESSORIES COMPATIBLE WITH P&H BUCKET DOOR

### ■ Minetec NCHP Latch Bar compatible with P&H dipper door:

- 4100 XPC
- 4100 XPB
- 2800
- 2300

Among other models.



**MINETEC LATCH BAR** PAT. PENDING

### ■ Minetec Latch Lever compatible with P&H dipper door:

- 4100 XPC
- 4100 XPB
- 2800
- 2300

Among other models.



**MINETEC LATCH LEVER**

### ■ Minetec Fullcrum Box compatible with P&H dipper door:

- 4100 XPC
- 4100 XPB
- 2800
- 2300

Among other models.



**MINETEC FULLCRUM**



# MINETEC BUSHINGS AND PINS

COMPATIBLE WITH P&H BUCKET / REF. 4100 XPC

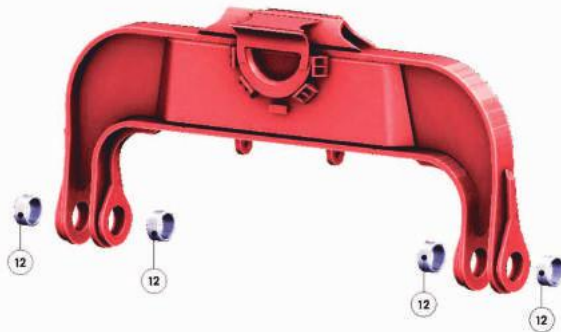
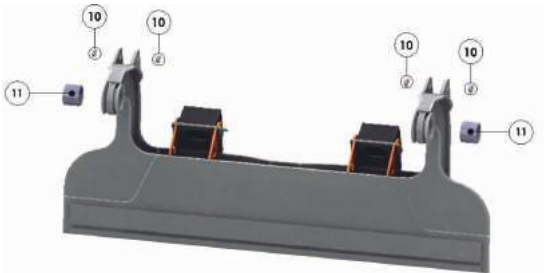

REF	DESCRIPTION	PART NUMBER	QTY	STEEL
1	BUSHING (DIPPER TO BAIL)	BPH_V2-4100XPC-MI-07-09A	2	MANGANESE STEEL
2	BUSHING (PITCH BRACE)	BPH_V2-4100XPC-MI-07-04A	4	MANGANESE STEEL
3	BUSHING (DIPPER TO DOOR)	BPH_V2-4100XPC-MI-07-06A	2	MANGANESE STEEL
4	BUSHING (DIPPER DOOR)	BPH_V2-4100XPC-MI-07-07A	4	MANGANESE STEEL
5	BUSHING (DIPPER DOOR)	BPH_V2-4100XPC-MI-07-08A	2	MANGANESE STEEL
6	PIN (BAIL)	BPH_V2-4100XPC-MI-07-07A	2	MANGANESE STEEL
7	PIN (PITCH BRACE)	BPH_V2-4100XPC-MI-07-05-00A	2	MANGANESE STEEL
8	PIN (DIPPER DOOR)	BPH_V2-4100XPC-MI-07-02A	2	MANGANESE STEEL
9	PIN (HANDLE)	BPH_V2-4100XPC-MI-07-03A	2	MANGANESE STEEL
10	BUSHING (SNUBBER)	BPH_V2-4100XPC-MI-07-16A	2	MANGANESE STEEL
11	BUSHING (DOOR)	BPH_V2-4100XPC-MI-07-17A	4	MANGANESE STEEL
12	BUSHING (BAIL)	BPH_V2-4100XPC-07-13A	4	MANGANESE STEEL

## MINETEC BUSHINGS AND PINS COMPATIBLE WITH P&H BUCKET

### ■ Minetec Pins compatible with P&H bucket and bucket dipper door:

- 4100 XPC
- 4100 XPB
- 2800
- 2300

Among other models.



**MINETEC PINS**

### ■ Minetec Bushings compatible with P&H bucket and bucket dipper door:

- 4100 XPC
- 4100 XPB
- 2800
- 2300

Among other models.

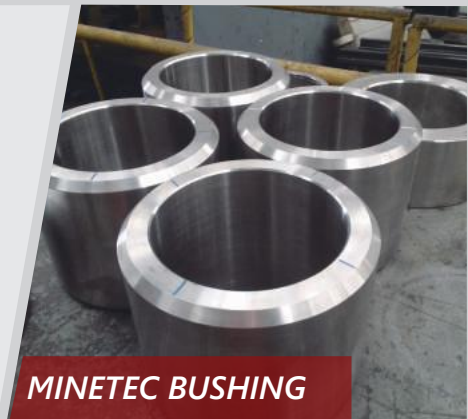

**MINETEC BUSHING**

### ■ Minetec Bucket Bushings compatible with P&H models:

- 4100 XPC
- 4100 XPB
- 2800
- 2300

Among other models.  
See designs concentric and eccentrics.

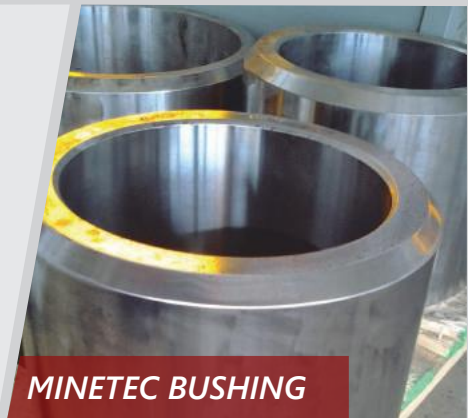

**MINETEC BUSHING**

# COMPONENT MANUFACTURE FOR ROPE SHOVELS

COMPATIBLE WITH SHOVELS CAT / BUCYRUS



MINETEC



**BALDE N.C.H.P.**  
NON CAST HIGH PERFORMANCE



MINETEC

# MAJOR COMPONENTS FOR ROPE SHOVELS COMPATIBLE WITH CAT / BUCYRUS SHOVELS

## ■ Minetec **NCHP** Bucket compatible with CAT / BUCYRUS shovels:

- 7495 / 495HR
- 7495HD
- 7395

Among other models.



## ■ Minetec Side Frame compatible with CAT / BUCYRUS shovels:

- 7495 / 495HR
- 7495HD
- 7395
- BII

Among other models.



## ■ Minetec NCHP Bucket Lip:

- Compatible with GETS WH 12 y S130

Among other models.

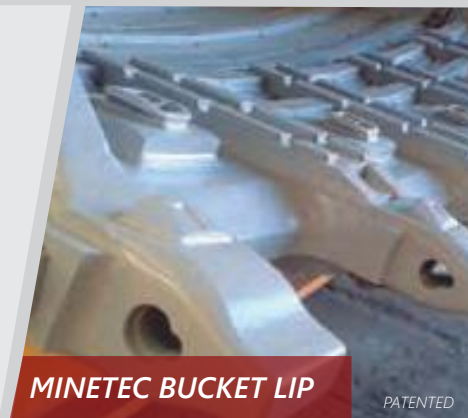

# PARTS AND PIECES MINETEC NCHP BUCKET

COMPATIBLE WITH CAT SHOVELS / REF. 7495

FOR OTHERS MODELS VISIT [WWW.MINE-TEC.COM](http://WWW.MINE-TEC.COM) OR CONTACT A MINETEC DEALER

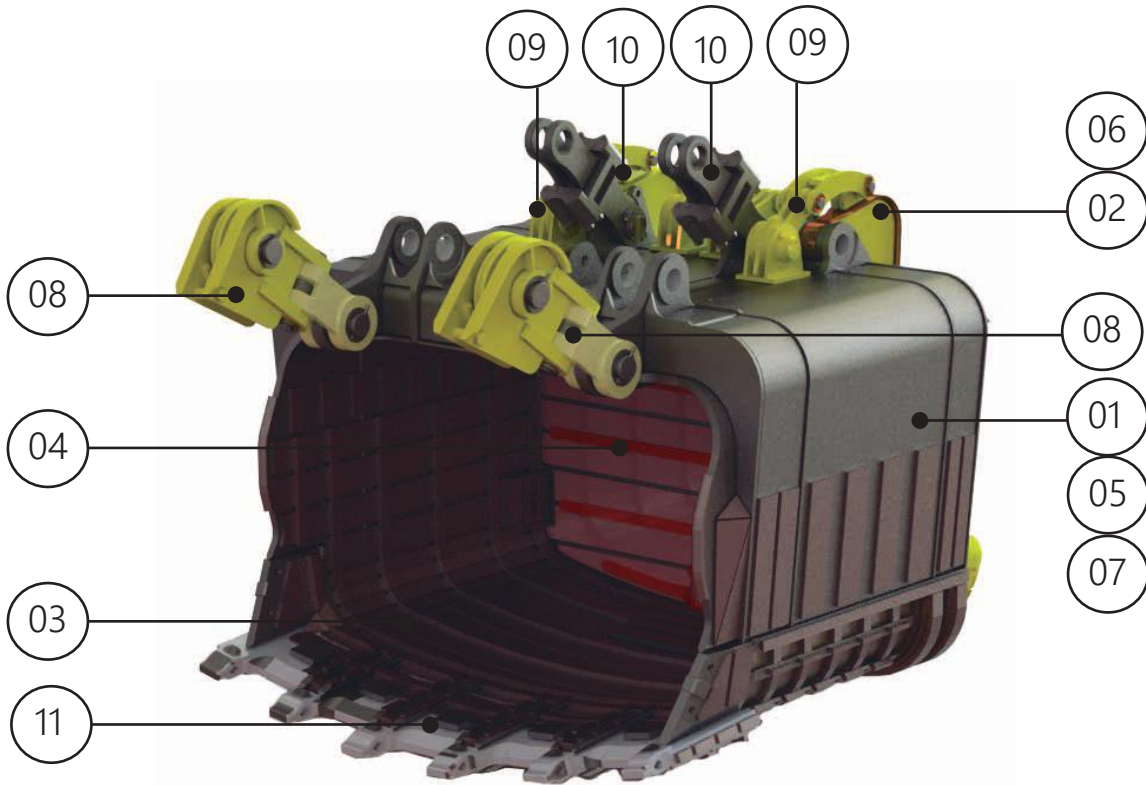

## MINETEC NCHP BUCKET / PART NUMBER BCT\_V2-7495-MI-00A

REF	DESCRIPTION	PART NUMBER	QTY
1	DIPPER BODY	BBC_V1-7495HR-MI-01-00A	1
2	DIPPER DOOR	BBC_V1-7495HR-MI-02-00A	1
3	BUCKET WEAR KIT	BBC_V1-7495HR-MI-03-00A	1
4	DOOR WEAR KIT	BBC_V1-7495HR-MI-04-00A	1
5	DIPPER ASSEMBLY	BBC_V1-7495HR-MI-05-00A	1
6	DOOR ASSEMBLY	BBC_V1-7495HR-MI-06-00A	1
7	BUSHINGS AND PINS	BBC_V1-7495HR-MI-07-00A	-
8	PADLOCK (RIGHT)	BBC_V1-7495HR-MI-08-00A-D	1
	PADLOCK (LEFT)	BBC_V1-7495HR-MI-08-00A-I	1
9	SNNUBER (RIGHT)	BBC_V1-7495HR-MI-09-00A-D	2
	SNNUBER (LEFT)	BBC_V1-7495HR-MI-09-00A-I	2
10	PITCH BRACE	BBC_V1-7495HR-MI-10-00A	2
11	DIPPER LIP	LBC_V2-7495HR-MI-00A	1

## PARTS AND PIECES

COMPATIBLE WITH CAT / BUCYRUS BUCKET

### ■ Minetec Dipper Door compatible with CAT / BUCYRUS bucket:

- 7495 / 495HR
- 7495HD
- 7395

Among other models.



**MINETEC DIPPER DOOR**

### ■ Minetec Padlock with CAT / BUCYRUS shovels:

- 7495 / 495HR
- 7495HD
- 7395

Among other models.



**MINETEC PADLOCK**

### ■ Minetec Snubber **SENSOR 2X / 4X** compatible with CAT / BUCYRUS shovels:

- 7495 / 495HR
- 7495HD
- 7395

Among other models.

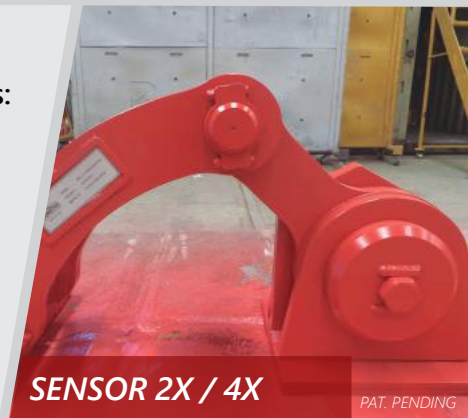

**SENSOR 2X / 4X**

PAT. PENDING

# PARTS AND PIECES MINETEC BUCKET DOOR COMPATIBLE WITH CAT BUCKET / REF. 7495

FOR OTHERS MODELS VISIT [WWW.MINE-TEC.COM](http://WWW.MINE-TEC.COM) OR CONTACT A MINETEC DEALER

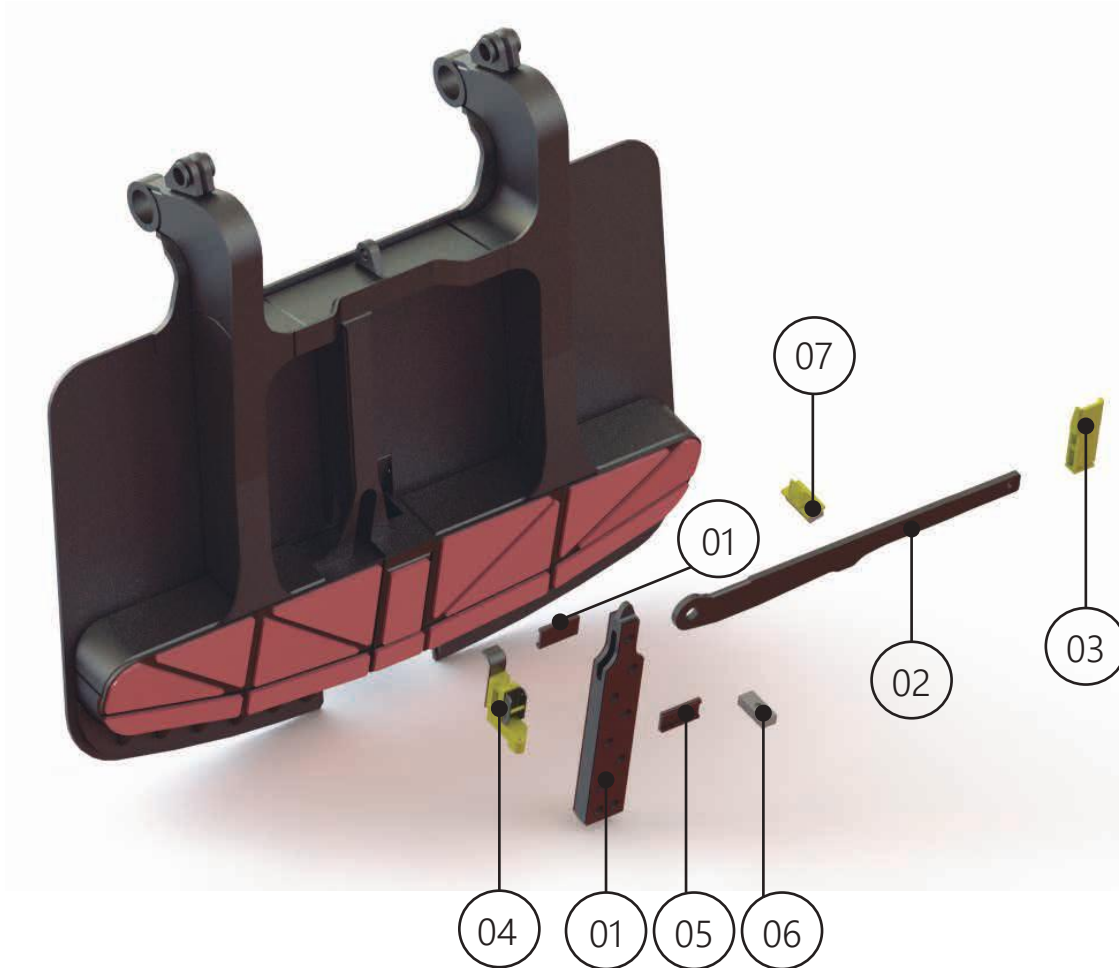

## MINETEC DIPPER DOOR WITH ACCESORIES / PART NUMBER BCT\_V2-7495-MI-06-00A

REF	DESCRIPTION	PART NUMBER	QTY
1	LATCH BAR	BBC_V1-7495HR-06-01-00A	1
2	LATCH LEVER	BBC_V1-7495HR-06-02-00A	1
3	TRIP ROPE BRACKET	BBC_V1-7495HR-06-03-00A	1
4	FULLCRUM BOX	BBC_V1-7495HR-06-04-00A	1
5	UPPER LATCH BAR GUIDE	BBC_V1-7495HR-06-05-00A	1
6	LOWER LATCH BUMPER	BBC_V1-7495HR-06-06-00A	1
7	UPPER LATCH BUMPER	BBC_V1-7495HR-06-07-00A	1

## SPARE PARTS AND ACCESSORIES COMPATIBLE WITH CAT / BUCYRUS BUCKET DOOR

### ■ Minetec NCHP Latch Bar for CAT / BUCYRUS dipper doors:

- 7495 / 495HR
- 7495HD
- 7395

Among other models.



**MINETEC LATCH BAR**

### ■ Minetec Latch Lever compatible with CAT / BUCYRUS dipper door:

- 7495 / 495HR
- 7495HD
- 7395

Among other models.



**MINETEC LATCH LEVER**

### ■ Minetec Fullcrum Box compatible with CAT / BUCYRUS dipper door:

- 7495 / 495HR
- 7495HD
- 7395

Among other models.



**MINETEC FULLCRUM**



# MINETEC BUSHINGS AND PINS

## COMPATIBLE WITH CAT BUCKET / REF. 7495



REF	DESCRIPTION	DIMENSIONS	PART NUMBER	QTY
1	CONCENTRIC BUSHING (DIPPER TO BAIL)	D.E. 11" x D.I. 8,5" x L 7"	BBC_V1-495-53-MI-07-01-01A	2
2	ECCENTRIC BUSHING 1/4	D.E. 11" x D.I. 8,5" x L 7"	BBC_V1-495-53-MI-07-01-02A	2
3	ECCENTRIC BUSHING 1/2	D.E. 11" x D.I. 8,5" x L 7"	BBC_V1-495-53-MI-07-01-03A	2
4	ECCENTRIC BUSHING 3/4	D.E. 11" x D.I. 8,5" x L 7"	BBC_V1-495-53-MI-07-01-04A	2
5	BUSHING (HANDLE)	D.E. 9,5" x D.I. 8" x L 6,75"	BBC_V1-495-53-MI-07-01-06A	2
6	BUSHING (HANDLE)	D.E. 9,5" x D.I. 8" x L 3,5"	BBC_V1-495-53-MI-07-01-07A	2
7	BUSHING (TO PITCH BRACE)	D.E. 9,5" x D.I. 8" x L 5"	BBC_V1-495-53-MI-07-01-08A	2
8	BUSHING (TO DOOR)	D.E. 9,5" x D.I. 8" x L 6"	BBC_V1-495-53-MI-07-01-09A	4
9	PIN (DIPPER DOOR)	D.E. 8" x L 26"	BBC_V1-495HR-MI-11-01-00A	2
10	PIN (HANDLE)	D.E. 8" x L 29,5"	BBC_V1-495HR-MI-11-02-00A	2
11	BUSHING (DOOR)	D.E. 9,5" x D.I. 8" x L 6,75"	BBC_V1-495-53-MI-07-02-01A	2
12	BUSHING (SNUBBER)	D.E. 5" x D.I. 4" x L 9,25"	BBC_V1-495-53-MI-07-02-02A	2

## MINETEC BUSHINGS AND PINS COMPATIBLE WITH CAT / BUCYRUS BUCKET

### ■ Minetec Pin compatible with CAT / BUCYRUS bucket:

- 7495 / 495HR
- 7495HD
- 7395

Among other models.

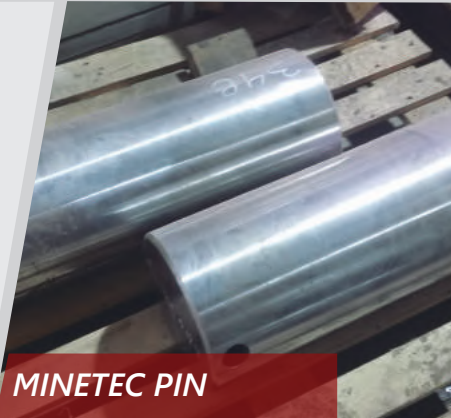

**MINETEC PIN**

### ■ Minetec Bushing compatible with CAT / BUCYRUS bucket:

- 7495 / 495HR
- 7495HD
- 7395

Among other models.

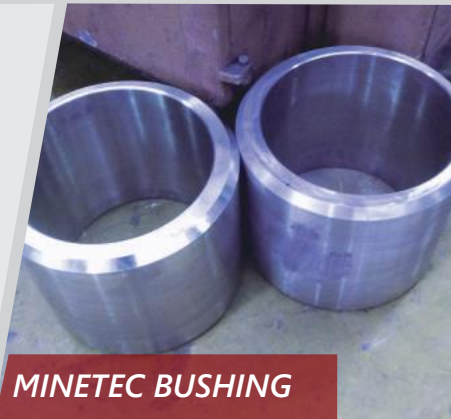

**MINETEC BUSHING**

### ■ Minetec Bushing compatible with CAT / BUCYRUS dipper door:

- 7495 / 495HR
- 7495HD
- 7395

Among other models.



**MINETEC BUSHING**

# COMPONENT MANUFACTURE FOR HYDRAULIC SHOVELS



**MINETEC N.C.H.P. FRONT SHOVEL BUCKET**  
NON CAST HIGH PERFORMANCE



**MINETEC N.C.H.P. BACKHOE BUCKET**  
NON CAST HIGH PERFORMANCE

  
**MINETEC**

# MAJOR COMPONENTS FOR HYDRAULIC SHOVELS

## ■ Minetec Bucket compatible with CAT hydraulic shovels (*FRONT SHOVEL* y *BACKHOE*):

- 6060
- 6050
- 6040
- 6030
- 6018

Among other models.



## ■ Minetec Bucket compatible with KOMATSU hydraulic shovels (*FRONT SHOVEL*):

- PC 8000 FS
- PC 5500 FS
- PC 4000 FS

Among other models.



## ■ Minetec Bucket compatible KOMATSU hydraulic shovels (*BACKHOE*):

- PC 8000 BH
- PC 5500 BH

Among other models.



## ■ Minetec Bucket compatible HITACHI hydraulic shovels:

- EX 8000 FS
- EX 5600 FS
- EX 3600 FS
- EX 2600 BH
- EX 1900 BH

Among other models.



# PARTS AND PIECES FOR MINETEC NCHP BUCKET COMPATIBLE WITH KOMATSU HYDRAULIC SHOVELS / REF. PC 5500

FOR OTHERS MODELS VISIT [WWW.MINE-TEC.COM](http://WWW.MINE-TEC.COM) OR CONTACT A MINETEC DEALER

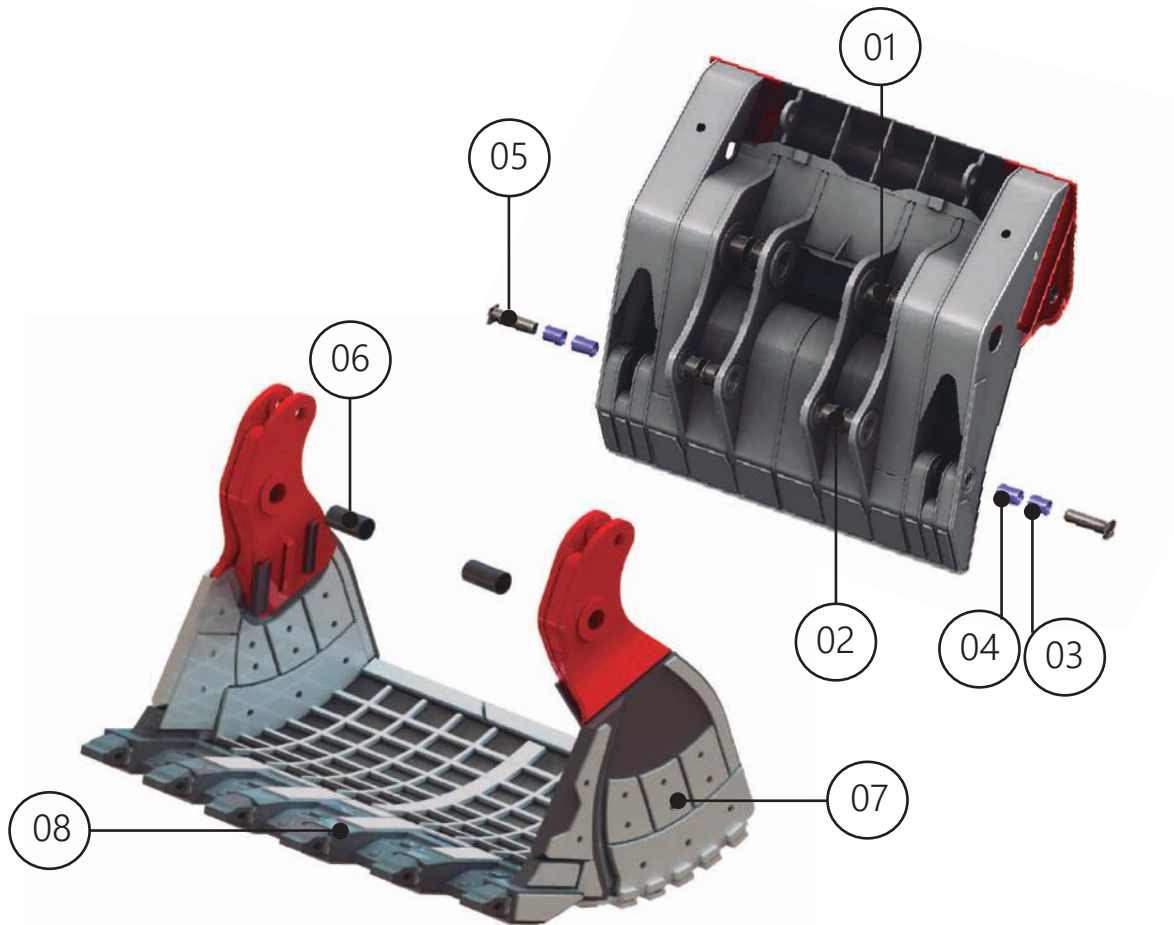

## MINETEC BUCKET / PART NUMBER BKS\_V2-5500-MI-00A

REF	DESCRIPTION	PART NUMBER	QTY
1	BUSHING (TO STICK)	BKS_V2-PC5500-MI-06-01A	4
2	BUSHING	BKS_V2-PC5500-MI-06-02A	4
3	BUSHING	BKS_V2-PC5500-MI-06-03A	2
4	BUSHING	BKS_V2-PC5500-MI-06-04A	2
5	PIN	BKS_V2-PC5500-MI-06-05A	2
6	PIN	BKS_V2-PC5500-MI-06-06A	2
7	BUCKET CLAM	BCT_V2-6060FS-MI-01-01A	2
8	BUCKET CLAM LIP	BCT_V2-6060FS-MI-01-02A	1

## SPEAR PARTS AND ACCESSORIES COMPATIBLE WITH HYDRAULIC SHOVELS

### ■ Minetec Bushing compatible with hydraulic shovels:

- CAT
- KOMATSU
- HITACHI
- LIEBHERR

Among other models.



### ■ Minetec Pin compatible with hydraulic shovels:

- CAT
- KOMATSU
- HITACHI
- LIEBHERR

Among other models.



### ■ Minetec NCHP Bucket Lip :

Compatible with GET

- S 110
- S 130
- S 145

Among other models.

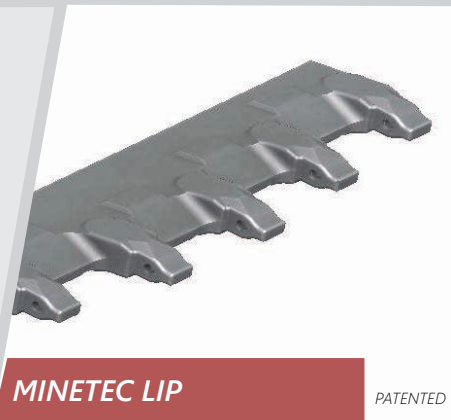

# COMPONENT MANUFACTURE FOR FRONT LOADERS



  
**MINETEC**

## MAJOR COMPONENTS FOR FRONT LOADERS

### ■ Minetec Bucket compatible with LETOURNEAU front loaders:

- L2350
- L1850
- L1400
- L950

Among other models.



*MINETEC BUCKET BLT 2350*

### ■ Minetec Bucket compatible with CAT front loaders:

- 988
- 992
- 994

Among other models.



*MINETEC BUCKET BCT 988*

### ■ Minetec Bucket compatible with KOMATSU front loaders:

- WA 1200
- WA 900
- WA 800
- WA 600

Among other models.



*MINETEC BUCKET BKS 1200*



# COMPONENT MANUFACTURE FOR DOZERS AND AUXILIARY MACHINERY



  
MINETEC

## MAJOR COMPONENT FOR DOZERS AND DRILLS

### ■ MINETEC DOZER BLADE

Compatible with:

- CAT
- KOMATSU

Among other models.

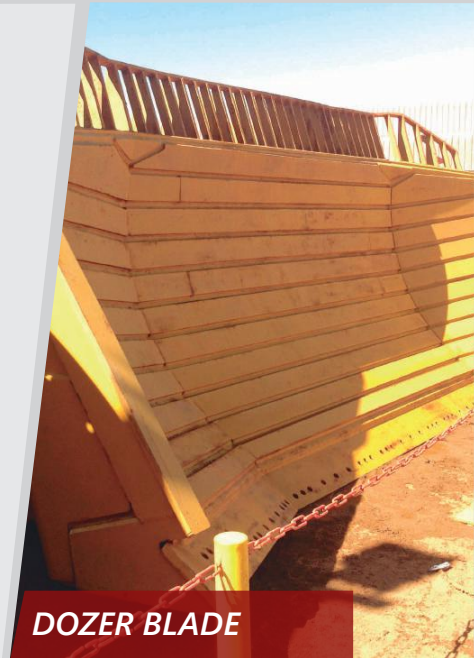

**DOZER BLADE**

### ■ MINETEC CRAWLER FRAME

Compatible with shovels and drills:

- CAT
- P&H
- VOLVO

Among other models.



**CRAWLER FRAME**

**G.E.T.**  
*GROUND ENGAGING TOOLS*  
*FIRST FIT*  
*SPARE PARTS*



**MINETEC**

**■ MTG adapters for rope shovels:**

- P&H
- CAT
- BUCYRUS

Among other models.

**■ MTG tip for rope and hydraulic shovels:**

- P&H
- CAT
- LETOURNEAU
- KOMATSU

Among other models.

**■ MTG adapters for hydraulic shovels:**

- KOMATSU
- CAT

Among other models.

**■ MTG tip for front loaders:**

- LETOURNEAU
- CAT
- KOMATSU

Among other models.





# TRANSPORT COMPONENTS



MINETEC



MINETEC

# DUMP TRAYS MANUFACTURE FOR MINING TRUCKS



**MINETEC**

# DUMP TRAY MANUFACTURE

## ■ MINETEC DUMP TRAYS G2

Special features include:

- Modern design
- Less carryback
- Less welded joints

**Compatible with mining trucks:**

- KOMATSU
- LIEBHERR
- HITACHI
- CAT

Among other models.



## ■ MINETEC DUMP TRAYS G3 "EASY-TRAY"

The Easy-Tray maintains the outstanding feature of the "G" series of Mintec, but adds extraordinary assembling and transport characteristics.



Assembled on site in two days.

**Compatible with mining trucks:**

- CAT
- LIEBHERR
- KOMATSU
- HITACHI

Among other models.





# MINETEC DUMP TRAYS WEAR KITS

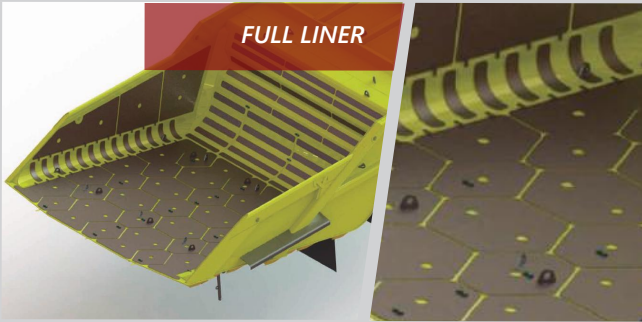

**FULL LINER**

## ■ FULL LINER

- FRONT AND SIDE, 10 mm. plates. 450 - 500 HB.
- FLOOR, 16 mm. plates. 450 - 500 HB.

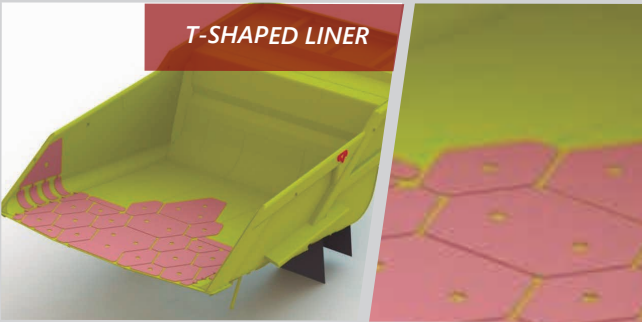

**T-SHAPED LINER**

## ■ T-SHAPED LINER

- SIDE, 10 mm. plates. 450 - 500 HB.
- FLOOR, 16 mm. plates. 450 - 500 HB.

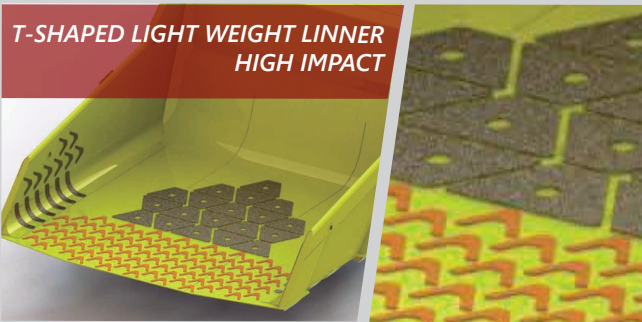

**T-SHAPED LIGHT WEIGHT LINER  
HIGH IMPACT**

## ■ T-SHAPED LIGHT WEIGHT LINER (HIGH IMPACT)

- SIDE, 10 mm. plates. 450 - 500 HB.
- FLOOR, 16 mm. plates. 450 - 500 HB.

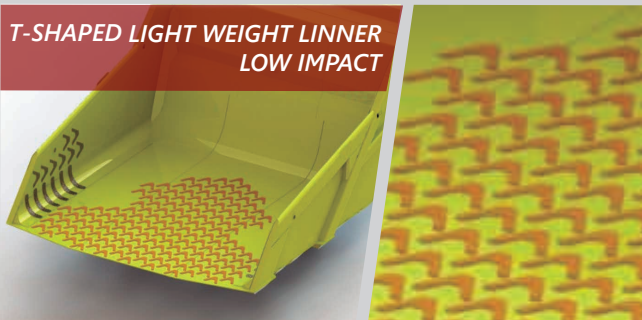

**T-SHAPED LIGHT WEIGHT LINER  
LOW IMPACT**

## ■ T-SHAPED LIGHT WEIGHT LINER (LOW IMPACT)

- SIDE, 10 mm. plates. 450 - 500 HB.
- FLOOR, 16 mm. plates. 450 - 500 HB.

## OTHER SPARE PARTS FOR MINETEC DUMP TRAYS

### ■ Minetec Body pads compatible with mining trucks:

- CAT
- KOMATSU
- HITACHI
- LIEBHERR

Among other models.



### ■ Safety cable bracket and rope:

- It provides extra safety in maintenance.



### ■ Light Bracket compatible with mining trucks:

- CAT
- KOMATSU
- HITACHI
- LIEBHERR

Among other models.



### ■ Fenders compatible with mining trucks:

- CAT
- KOMATSU
- HITACHI
- LIEBHERR

Among other models.



# MINING TRUCK WATER TANK MANUFACTURE AND AUXILIARY EQUIPMENT

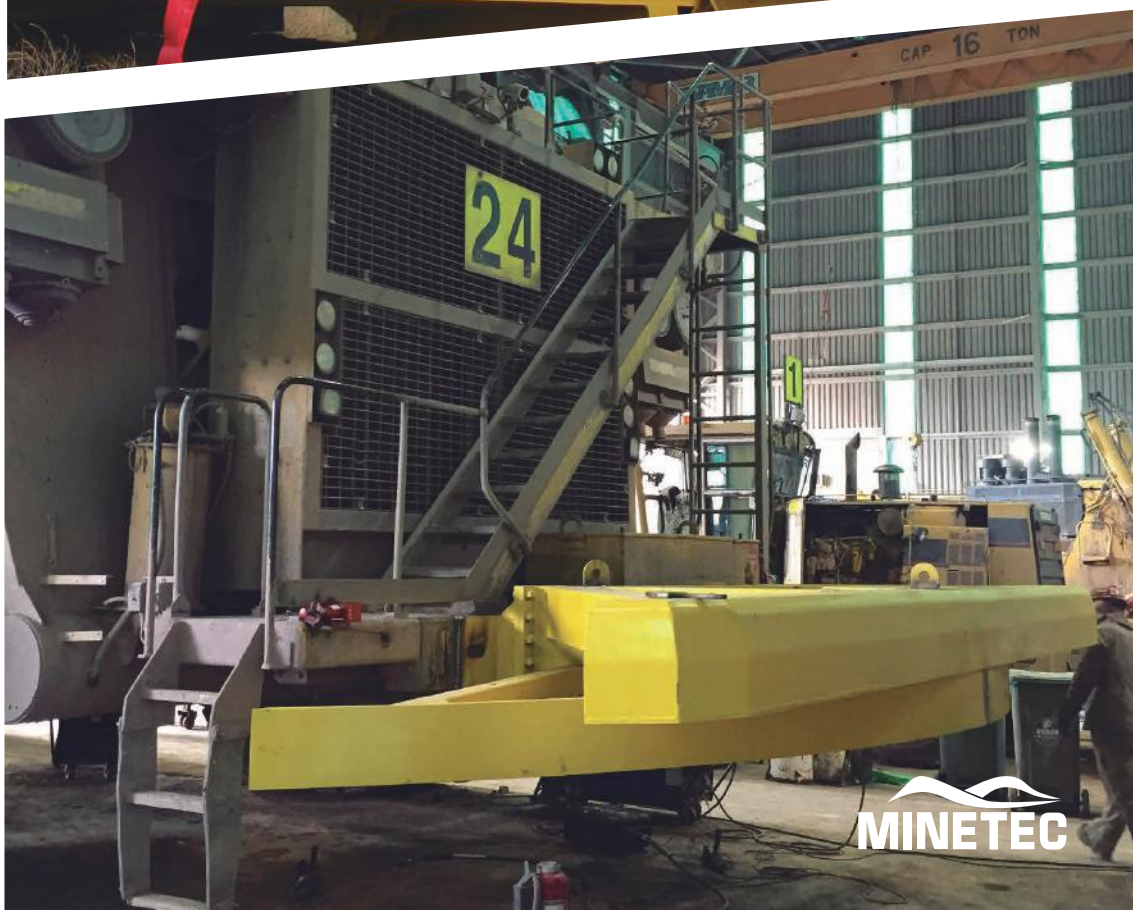

# MINING TRUCK WATER TANK MANUFACTURE AND AUXILIARY EQUIPMENT

## ■ Minetec Mining Truck Water Tank compatible with mining trucks:

- CAT
- KOMATSU
- LIEBHERR
- HITACHI

Among other models.



**MINING TRUCK WATER TANK**

## ■ Minetec Mining Truck Bumpers compatible with mining trucks:

For cabin safety in case of collision:

- CAT
- KOMATSU
- LIEBHERR
- HITACHI

Among other models.

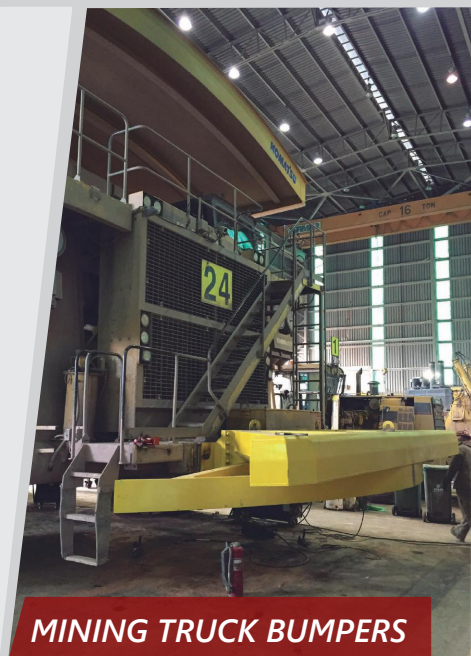

**MINING TRUCK BUMPERS**



# MINETEC SERVICE



  
**MINETEC**

# SERVICE CENTERS

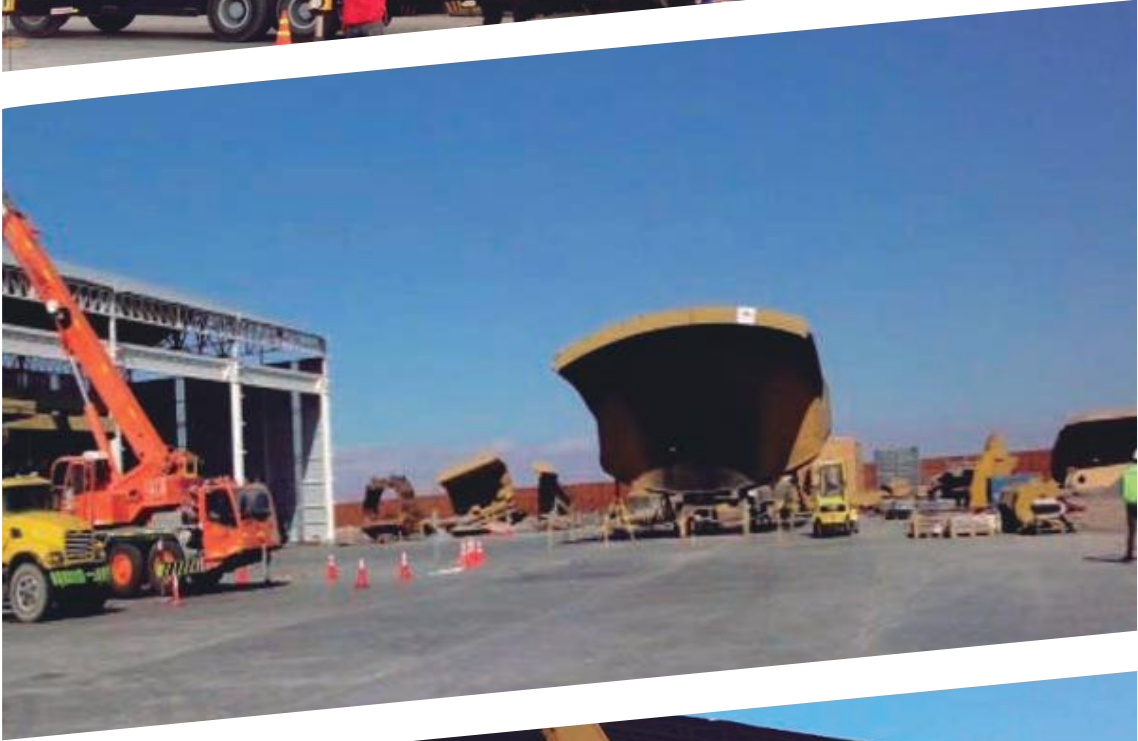

**MINETEC**

Near high demanding mine customers, MINETEC has installed major repair steel shops, named SERVICE CENTERS, as well as Distribution Centers for those mines needing quick supplies for the earthmoving equipment.

### ***SERVICE CENTERS OPERATIONS:***

- Rope Shovel Buckets overhauls, Hydraulic shovel bucket overhauls, front loader buckets major repair, Mining truck Dump Tray Overhaul.
- Major repairs and overhauls for shovel booms and dipper handles, drill towers, crawler frames, among others



**LO BOZA, CHILE**



**POZO ALMONTE, CHILE**



## SERVICE CENTERS



*CALAMA, CHILE*



*EL MELÓN, CHILE*



*TETE, MOZAMBIQUE*

New SERVICE CENTERS are being built in new locations in the following months.

**America**

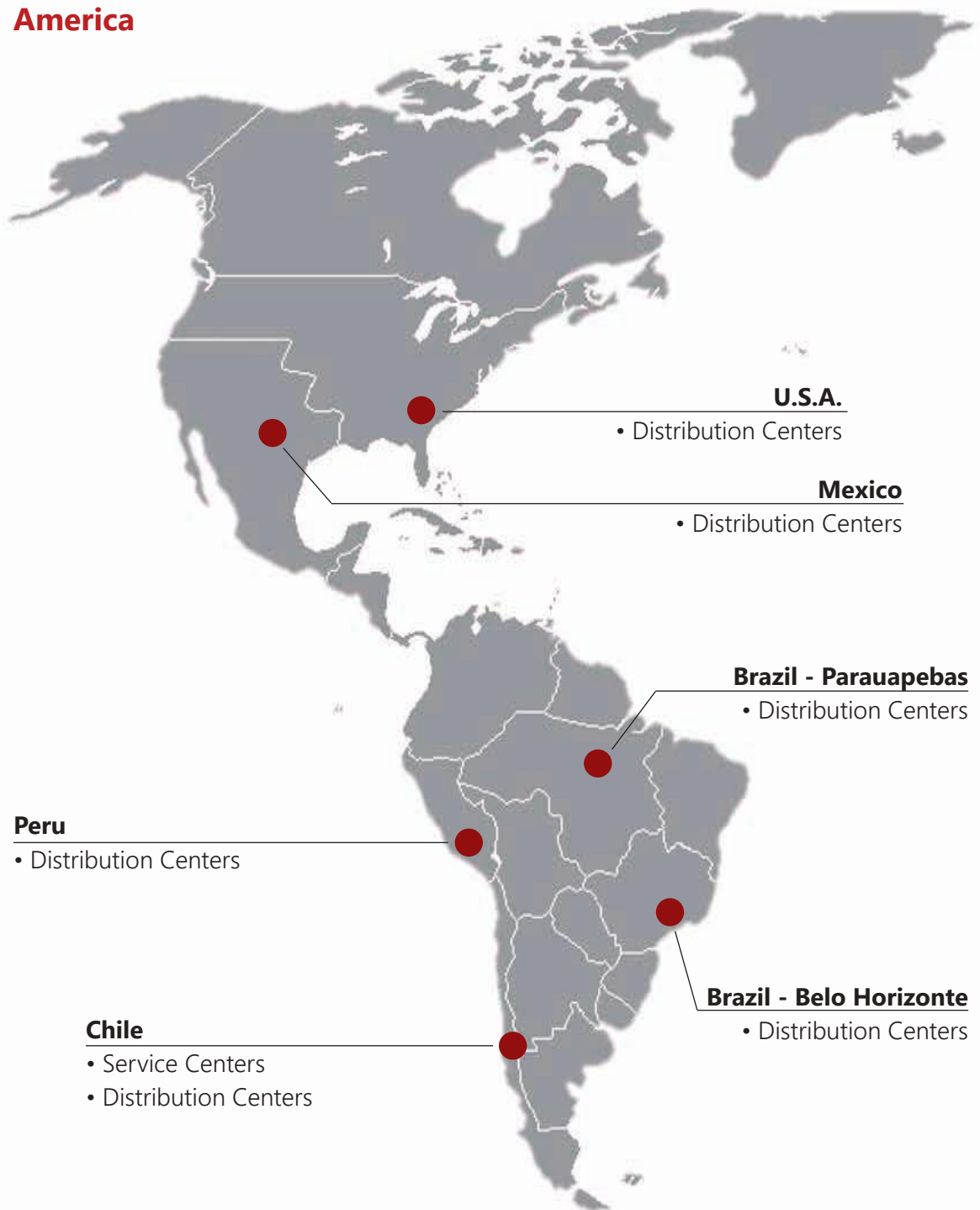

**Africa y Europa**

**Belarus (C.I.S. Countries)**

- Distribution Centers



**Mozambique**

- Service Centers
- Distribution Centers

**Asia and Oceania**

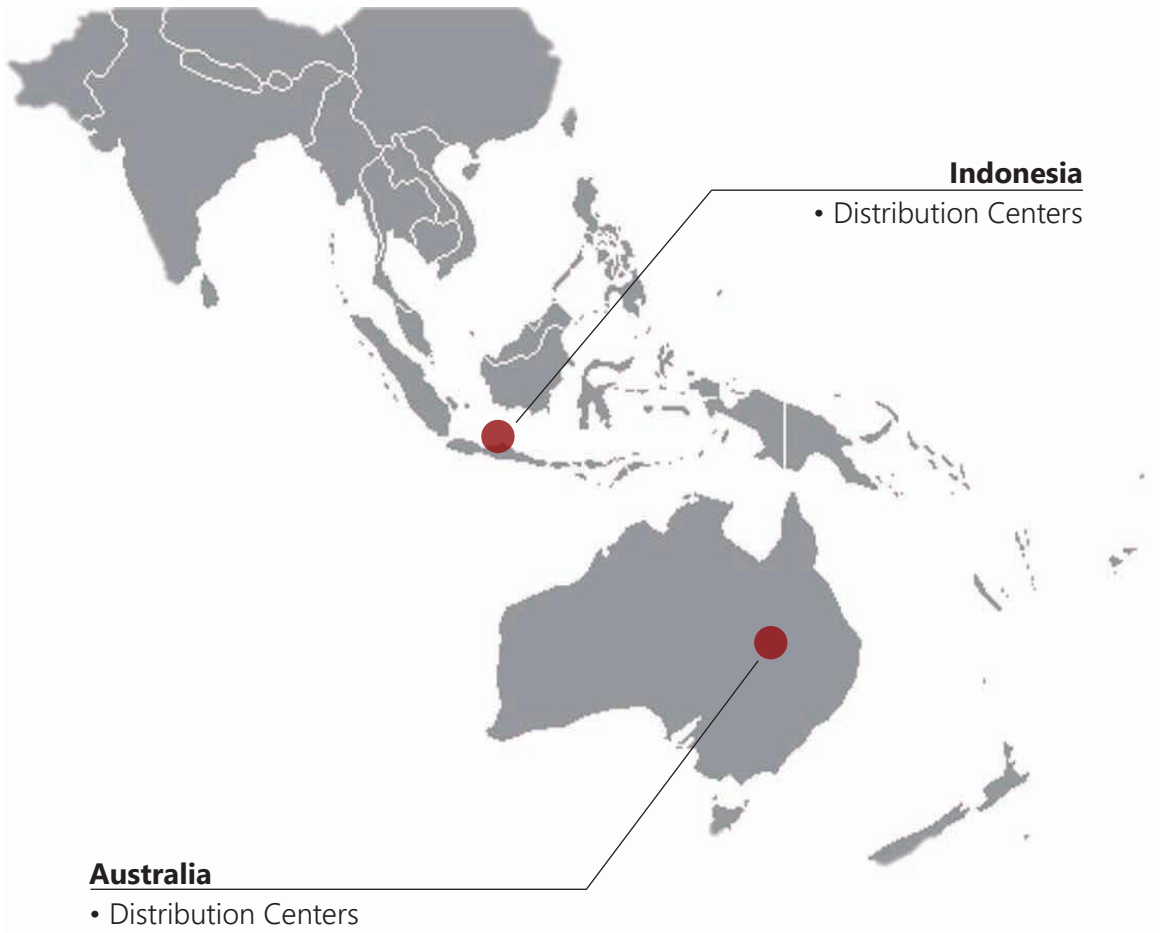

# ON-SITE MAINTENANCE



## ON-MINE-SITE MAINTENANCE SERVICE

MINETEC operates On-mine-site maintenance contracts for its customers, applying its knowledge and technology to support the mining equipment and maximize the availability of them for the mining operations.

■ MAJOR EQUIPMENT AND COMPONENT ASSEMBLY:  
Disassemble, assemble, overhaul, component fixing and commissioning for shovels, loaders, trucks, drills and auxiliary equipments.



Overhaul, assembly, and commissioning of a Bucyrus Shovel at Los Bronces mine, Anglo American, Chile, performed by the MINETEC team.

## ON-MINE-SITE MAINTENANCE SERVICE



### ■ Dump Tray Assembly Service:

- Assembly of new dump trays
- Replacement and mounting of the dump tray on the truck
- On site assistance of mining truck repair
- On site wear lining replacement and/or re-enforcements



### ■ Bucket Assembly Service:

- Assistance in the replacement or mounting of the bucket to the shovels and loaders
- Replacements of bushings, pins, accessories and liners.



### ■ G.E.T. maintenance:

- Assembly and replacement
- Failure analysis
- Life cycle and monitoring analysis
- Old parts recycling
- Operations improvement analysis

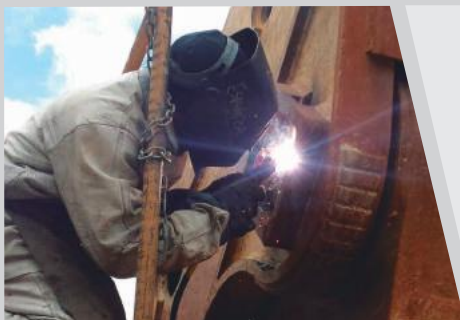

### ■ Structural Repairs:

MINETEC has qualified personnel that work together with the customer to maintain a high equipment availability, by attending and repairing the structural contingency damages that occur during the operation

# ON-MINE-SITE MAINTENANCE SERVICE



## ■ Transportation of Large Equipment:

- Transportation in the mine itself.
- Transportation from/to the port or shop.
- Special transportation permits and studies.



## ■ Crane and Special Lift Services:

- High Load cranes
- Specialized Hydraulic lifting equipment

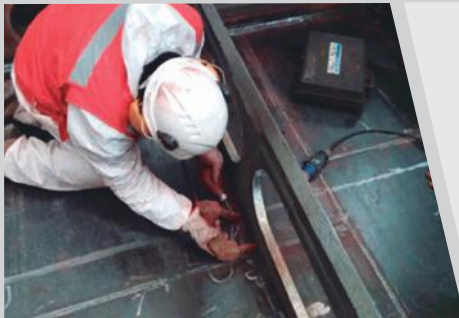

## ■ Quality Control and Specialized On site Inspection:

- Dimensional control
- Non destructive testings and strain gage analysis
- On site steel structural stress relief
- Wear rate sensing and monitoring for component



## ■ OTR Tire Repair Maintenance

- Preventive failure Maintenance
- OTR repair for mining trucks and wheel loaders
- On site minor and major tire retreading
- Permanent on site tire monitoring
- Continuous improvement analysis reports





  
**MINETEC**

